

# AUTOMOTIVE CURRENT TRANSDUCER OPEN LOOP TECHNOLOGY

## HABT 100-V/SP10



### Introduction

The HABT 100-V/SP20 current transducer is attached on the battery cable (or bus-bar) of a vehicle. It provides to an engine control unit (ECU) the actual value of current flowing in the cable via a voltage signal and the ambient temperature by an NTC thermistor. The transducer is linked to the ECU with the wiring harness using a waterproof connector. The output voltage  $V_{OUT}$  is fully ratiometric with the supply voltage  $U_C$ .

### Features

- Open Loop transducer using the Hall effect
- Unipolar + 5 V DC power supply
- Primary current measuring range up to  $\pm 100$  A
- Maximum RMS primary admissible current: limited by the cable, the magnetic core or the ASIC temperature  $T^\circ < + 150$  °C
- Operating temperature range:  $- 30$  °C  $< T^\circ < + 90$  °C
- Output voltage: fully ratio-metric (in sensitivity and offset)
- Temperature measurement by embedded NTC.

### Advantages

- Excellent accuracy
- Very good linearity
- Very low thermal offset drift
- Very low thermal sensitivity drift
- Current & Temperature measurement
- No insertion losses.

### Automotive applications

- Battery monitoring
- HEV application
- EV application.

### Principle of HABT Family

Open loop transducers use a Hall effect integrated circuit. The magnetic flux density  $B$ , contributing to the rise of the Hall voltage, is generated by the primary current  $I_p$  to be measured. The current to be measured  $I_p$  is supplied by a current source i.e. battery or generator (Figure 1).

Within the linear region of the hysteresis cycle,  $B$  is proportional to:

$$B(I_p) = \text{constant}(a) \times I_p$$

The Hall voltage is thus expressed by:

$$V_H = (R_H/d) \times I \times \text{constant}(a) \times I_p$$

Except for  $I_p$ , all terms of this equation are constant. Therefore:

$$V_H = \text{constant}(b) \times I_p$$

The measurement signal  $V_H$  amplified to supply the user output voltage or current.

Fig. 1: Principle of the open loop transducer

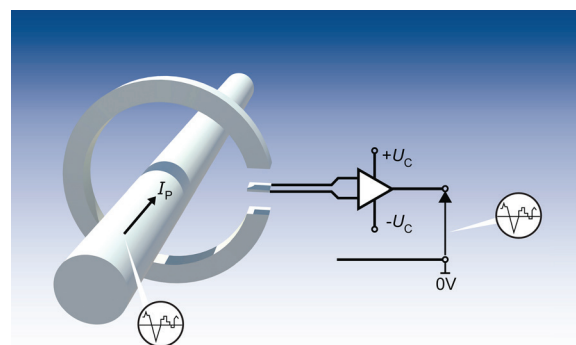

## Dimensions HABT 100-V/SP10 (in mm)

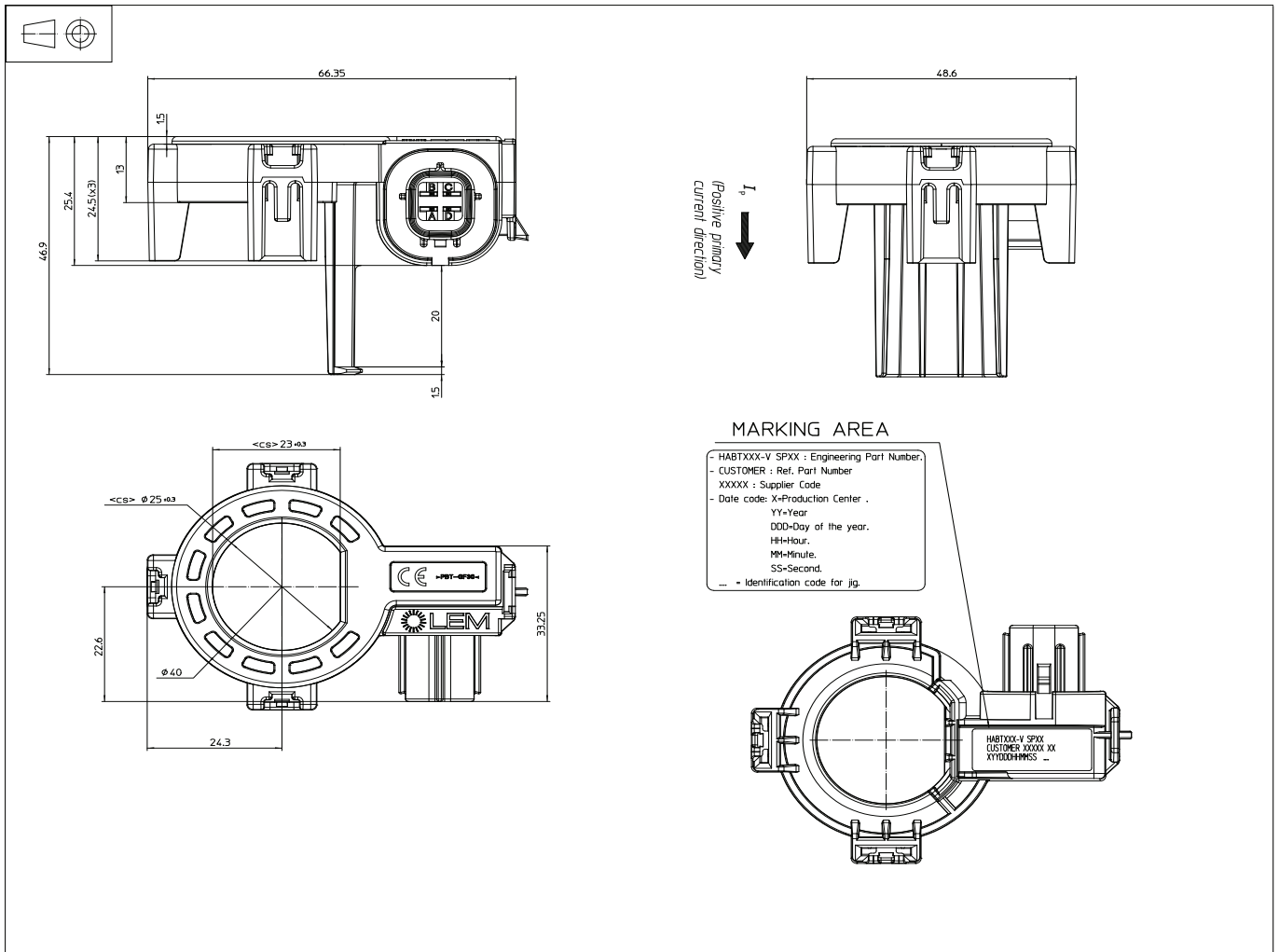

### Mechanical characteristics

- Plastic case >PBT-GF30<
- Magnetic core Ferromagnetic alloy
- Pins Gold plated

### Remarks

- $I_p = \left( \frac{5}{U_c} \cdot V_{out} - V_0 \right) \cdot \frac{1}{G}$  with  $G$  in (V/A)
- $V_{out} > V_0$  when  $I_p$  flows in the positive direction (see arrow on drawing).

### System architecture

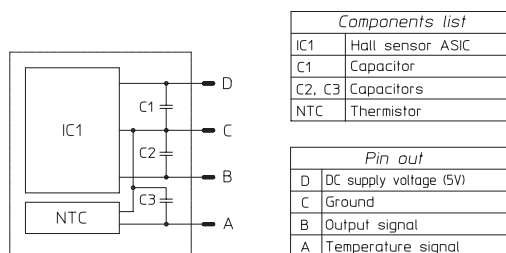

### System architecture (example)

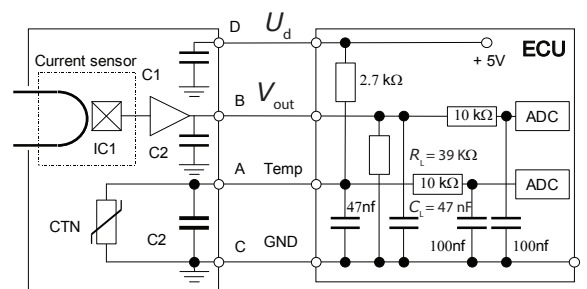

## HABT 100-V/SP10

### Absolute ratings (not operating)

Parameter	Symbol	Unit	Specification			Conditions
			Min	Typical	Max	
Nominal supply voltage	$U_C$	V	4.5	5	5.5	
Supply continuous over voltage					8.5	
Reverse voltage			- 14			1 min @ $T_A = 25\text{ °C}$
Over voltage					14	2 min
Continuous output voltage	$V_{out}$	V			14	1 min @ $T_A = 25\text{ °C}$
Continuous output current	$I_{out}$	mA	- 10		10	
Maximum Output short circuit duration	$t_c$	min			2	
Insulation resistance	$R_{IS}$	MΩ	10			DC 500 V
Ambient storage temperature	$T_s$	°C	- 40		100	

### Operating characteristics in nominal range ( $I_{PN}$ )

Parameter	Symbol	Unit	Specification			Conditions
			Min	Typical	Max	
<b>Electrical Data</b>						
Supply voltage	$U_C$	V	4.5	5	5.5	
Continuous output current	$I_{out}$	mA	- 1		1	
Sensitivity error	$\epsilon_G$	%		± 0.5		
Load resistance	$R_L$	KΩ	9	10	100	
Capacitive loading	$C_L$	nF		10	100	
Ambient operating temperature	$T_A$	°C	- 30		90	
Output voltage (diagnostic detection open ground)	$V_{out}$	V			0.15	
Output voltage (diagnostic detection open $U_C$ )	$V_{out}$	V			0.15	
<b>Performance Data</b>						
Current consumption	$I_C$	mA	5	7	10	@ $T_A = 25\text{ °C}$ Over temperature
Linearity error	$\epsilon_L$	%	- 0.5		0.5	Up to 80 A <sup>(2)</sup>
			- 1		1	Up to 100 A <sup>(2)</sup>
Overall accuracy @ $I = 0\text{ A}$ @ - 30 to 90 °C	$X_G$	A	- 0.7		0.7	$V_{out} = \pm 14\text{ mV}$ ; @ $U_C = 5\text{ V} \pm 0.05\text{ V}$
Overall accuracy @ $I = 100\text{ A}$ @ - 30 to 90 °C			- 3.75		3.75	$V_{out} = \pm 75\text{ mV}$ ; @ $U_C = 5\text{ V} \pm 0.05\text{ V}$
Sensitivity	$G$	mVA		20		
Global offset current	$I_O$	mA	- 300		300	@ $T_A = 25\text{ °C}$
Electrical offset current	$I_{OE}$	mA	- 250		250	@ $T_A = 25\text{ °C}$
Magnetic offset current	$I_{OM}$	mA	- 200		200	@ $T_A = 25\text{ °C}$
Primary current, measuring range	$I_{PM}$	A	- 100		100	
Output voltage @ $I_p = 0$	$V_{out}$	V		$U_C / 2$		
Resolution		mV		2.5		
Output internal resistance	$R_{out}$	Ω		1	10	@ $T_A = 25\text{ °C}$ Over temperature
Step response time to 90 % $I_{PN}$ <sup>(1)</sup>	$t_r$	μs			1.1	
Power up time				25	200	
Settling time after overload					25	
Negative temperature coefficient resistance	$R_{NTC}$	KΩ	2.178	2.2	2.222	Accuracy ± 1 % @ $T_A = 25\text{ °C}$
B 25/85 constant			3485	3520	3555	Accuracy ± 1 %
Output clamping voltage low	$V_{SZ}$	% $U_C$	5.1	6	6.9	
Output clamping voltage high			92.1	93	93.9	
Temperature accuracy		°C	- 2		2	- 40/90 °C power off

Notes: <sup>1)</sup> With internal filter adjusted at 50 Hz  
<sup>2)</sup> LEM standard 98.20.00.370.0 method2.

## HABT 100-V/SP10

### Global Error

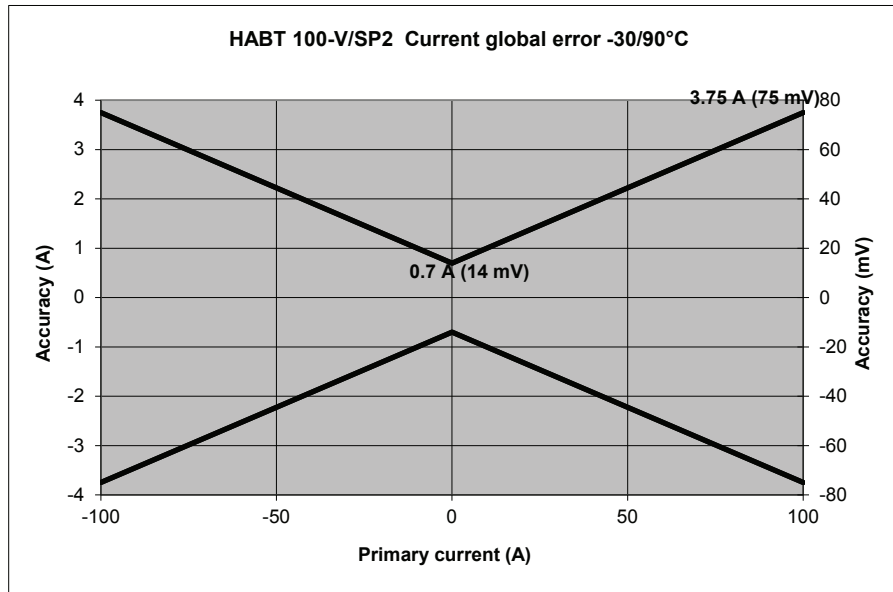

### Output and clamping

$$I_p = \left( \frac{5}{U_c} \cdot V_{out} - V_o \right) \cdot \frac{1}{G} \text{ with } G \text{ in (V/A)}$$

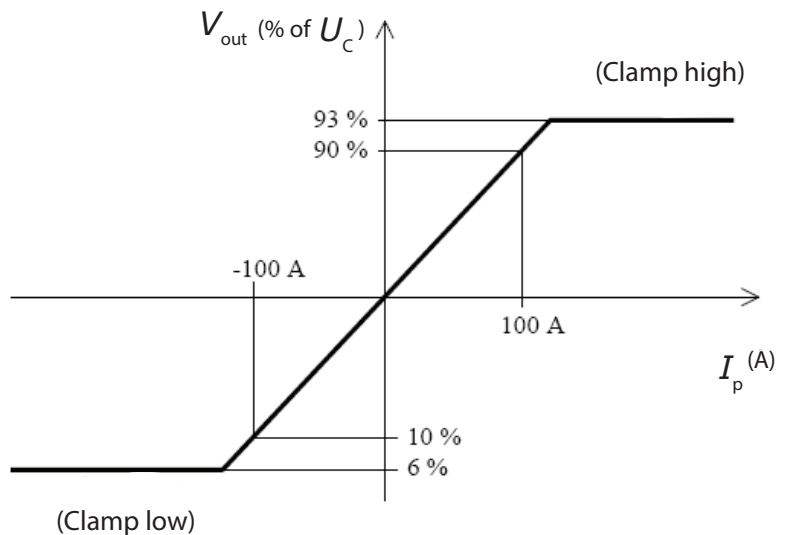

### Temperature output

Simplified formula:

$$T^{\circ}\text{C} = 3520 / (\ln(R_{NTC}/2200) + 3520/298.15) - 273.15$$

$$R_{NTC} = R \times U_{NTC} / (U_c - U_{NTC})$$

Complete formula:

$$1/T^{\circ}\text{K} = A1 + B1 \cdot \ln(R_{ntc}/2200) + C1 \cdot \ln(R_{ntc}/2200)^2 + D1 \cdot \ln(R_{ntc}/2200)^3$$

with A1 = 0.003354016

B1 = 0.0002866670

C1 = 1.563433 e<sup>-6</sup>

D1 = 1.327213 e<sup>-7</sup>

and T °C = T °K - 273.15

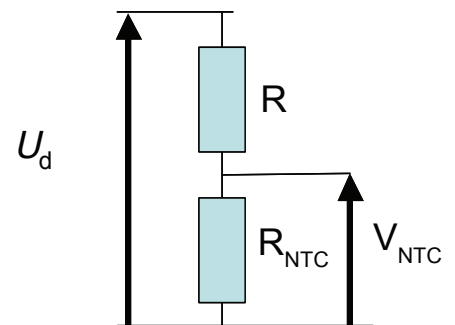

## HABT 100-V/SP10

### PERFORMANCES PARAMETERS DEFINITIONS

#### Primary current definition:

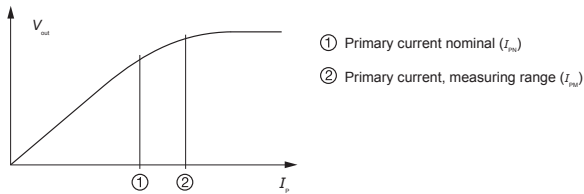

#### Definition of typical, minimum and maximum values:

Minimum and maximum values for specified limiting and safety conditions have to be understood as such as well as values shown in “typical” graphs. On the other hand, measured values are part of a statistical distribution that can be specified by an interval with upper and lower limits and a probability for measured values to lie within this interval. Unless otherwise stated (e.g. “100 % tested”), the LEM definition for such intervals designated with “min” and “max” is that the probability for values of samples to lie in this interval is 99.73 %. For a normal (Gaussian) distribution, this corresponds to an interval between -3 sigma and +3 sigma. If “typical” values are not obviously mean or average values, those values are defined to delimit intervals with a probability of 68.27 %, corresponding to an interval between -sigma and +sigma for a normal distribution. Typical, minimum and maximum values are determined during the initial characterization of a product.

#### Output noise voltage:

The output voltage noise is the result of the noise floor of the Hall elements and the linear amplifier.

#### Magnetic offset:

The magnetic offset is the consequence of an over-current on the primary side. It's defined after an excursion of  $I_{PN}$ .

#### Linearity:

The maximum positive or negative discrepancy with a reference straight line  $V_{out} = f(I_p)$ .

Unit: linearity (%) expressed with full scale of  $I_{PN}$ .

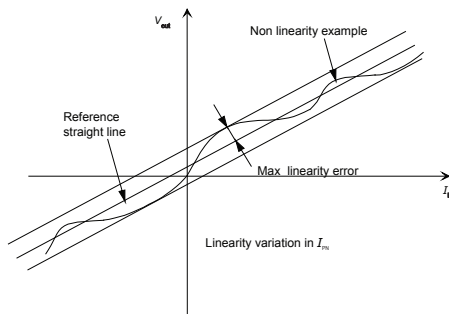

#### Response time (delay time) $t_r$ :

The time between the primary current signal ( $I_{PN}$ ) and the output signal reach at 90 % of its final value.

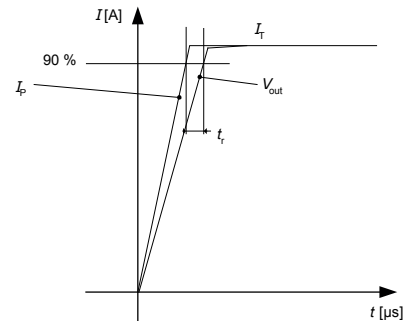

#### Sensitivity:

The Transducer's sensitivity  $G$  is the slope of the straight line

$V_{out} = f(I_p)$ , it must establish the relation:

$$V_{out}(I_p) = U_C/5 (G \cdot I_p + V_O)$$

#### Offset with temperature:

The error of the offset in the operating temperature is the variation of the offset in the temperature considered with the initial offset at 25 °C.

The offset variation  $I_{OT}$  is a maximum variation the offset in the temperature range:

$$I_{OT} = I_{OE \max} - I_{OE \min}$$

The Offset drift  $TCI_{OEAV}$  is the  $I_{OT}$  value divided by the temperature range.

#### Sensitivity with temperature:

The error of the sensitivity in the operating temperature is the relative variation of sensitivity with the temperature considered with the initial offset at 25 °C.

The sensitivity variation  $G_T$  is the maximum variation (in ppm or %) of the sensitivity in the temperature range:

$$G_T = (\text{Sensitivity max} - \text{Sensitivity min}) / \text{Sensitivity at } 25 \text{ }^\circ\text{C}$$

The sensitivity drift  $TCG_{AV}$  is the  $G_T$  value divided by the temperature range. Deeper and detailed info available is our LEM technical sales offices ([www.lem.com](http://www.lem.com)).

#### Offset voltage @ $I_p = 0 \text{ A}$ :

The offset voltage is the output voltage when the primary current is null. The ideal value of  $V_O$  is  $U_C/2$  at  $U_C = 5 \text{ V}$ . So, the difference of  $V_O - U_C/2$  is called the total offset voltage error. This offset error can be attributed to the electrical offset (due to the resolution of the ASIC quiescent voltage trimming), the magnetic offset, the thermal drift and the thermal hysteresis. Deeper and detailed info available is our LEM technical sales offices ([www.lem.com](http://www.lem.com)).

## HABT 100-V/SP10

### Environmental test specifications:

Immunity to conducted disturbance test		
Resistance to bulk current injection (BCI)	TOYOTA TCS7006G rev5 (2010)	60 mA Class A, 100 mA Class A, 200 mA Class B
Immunity to radiated disturbance tests		
Immunity to radiated electromagnetic field	TOYOTA TCS7006G rev5 (2010)	30 V/m, 60 V/m, 100V/m. 1 MHz-400MHz-2GHz. Class A 200 V/m. 1 MHz-400 MHz-2GHz. Class B
Emission of radio frequency energy: radiated	TOYOTA TCS7026G rev4 (2008)	30 MHz to 1GHz
Resistance to electrostatic discharge tests		
Resistance to electrostatic discharges, equipment not supplied	IEC 61000-4-2 (2001) Nissan 28401 NDS02 (2008) EQ/IR03 C = 150 pF; R = 330 Ohms	± 4 kV Contact discharge: Class A ± 8 kV Contact discharge: Class A ± 15 kV Air discharge: Class A
Resistance to electrostatic discharges, equipment supplied	Nissan 28401 NDS02 (2008) EQ/IR04 ISO 10605 (2001)	± 4 kV Contact discharge: Class A ± 8 kV Contact discharge: Class A ± 4 kV Air discharge: Class A ± 8 kV Air discharge: Class A ± 15 kV Air discharge: Class A ± 25 kV Air discharge: Class A
Electrical tests		
Engine starting voltage test		6 to 8 V, 1 Hz
Voltage dips tests		1, 5, 10, 15 and 20 ms
Reversed power connection test		13 V/1 min
Environmental tests		
Low T °C storage test		Not powered, - 40 °C, 96 ± 2 H
Low T °C operation test		- 30 °C, 192 H, powered
High T °C storage test		No powered, 100 °C ± 3.96 H
High T °C operation test		+ 90 °C ± 3, 192 H, powered
Temperature cycle test		30 cycles, 90 °C to - 30 °C, operational 5 H and non operational 1 H (180 H)
Thermal shock		- 40 °C/+90 °C with 2000 H (30 min + 30 min) no powered
Temperature humidity cycle test		
Constant humidity test		+ 60 °C / 90 % RH, 96 H, powered
Vibration in temperature		Resonance point detection 3 g, 5 to 200 Hz, sweep 10 min, 4+2+2 H
Impact test		Free fall @ 1 m, 3 times for each 5 planes, 15 times for connector plane on concrete
Dew condensation test		2 H @ - 5 °C and 10 Min @ 85 % RH @ 35 °C no operational
Temperature humidity cycle		1000 H 85 °C/ 85 % HR
Salt spray test	JIS Z 2371	Test according to JIS Z 2371. Leave transducers for 300H at ambient temperature of 35 ± 3 °C
Dipping test		Storage temperature 80 ± 3 °C, storage time 1H mini water temperature 25 ± 10 °C Dip depth: 100 mm dipping time 1 min No water immersion into inside of connector
Spray frost test	JIS D 0203 R2e	Spray frost Conform to JIS D 0203 R2e
Vibration durability		Ambient temperature 80 ± 3 °C, Frequency 20 to 200 Hz, Sweep time: 2 min, Acceleration 43.12 m·s <sup>-2</sup> , Time: 3 hours for each directions (top/bottom, left/right front/back), Power voltage 5 ± 2 V, measured current: 50 to - 100 A
Chemical proof test		Chemical temperature: 25 ± 10 °C Dipping time: 1 min Exposenal temperature: 80 ± 3 °C exposal time: 1H min Chemical name: Gasoline, engine, oil, brake oil, anti-freeze fluid. Torque converter oil. Washer fluid. Battery fluid. CRC. WAX WAX remover. PS. Oil.