

Click to view price, real time Inventory,  
Delivery & Lifecycle Information ;

## G-MRCO-037

TE Connectivity

Magneto-resistive Sensor Angle External Magnet, Not Included  
Gull Wing

Any questions, please feel free to contact us.  
[info@kaimte.com](mailto:info@kaimte.com)

# KMT32B Magnetic Angle Sensor

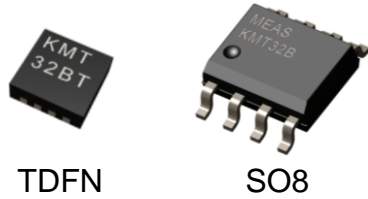

TDFN

SO8

- AMR Sensor with 180° period
- high accuracy
- high resolution
- for the use at moderate field strengths
- tiny TDFN package
- ROHS & REACH compliant

## DESCRIPTION

The KMT32B is a magnetic field sensor based on the anisotropic magneto resistance effect, i.e. it is sensing the **magnetic field direction** independently on the magnetic field strength for applied field strengths  $H > 25$  kA/m. The sensor contains two parallel supplied Wheatstone bridges, which enclose a sensitive angle of 45 degrees.

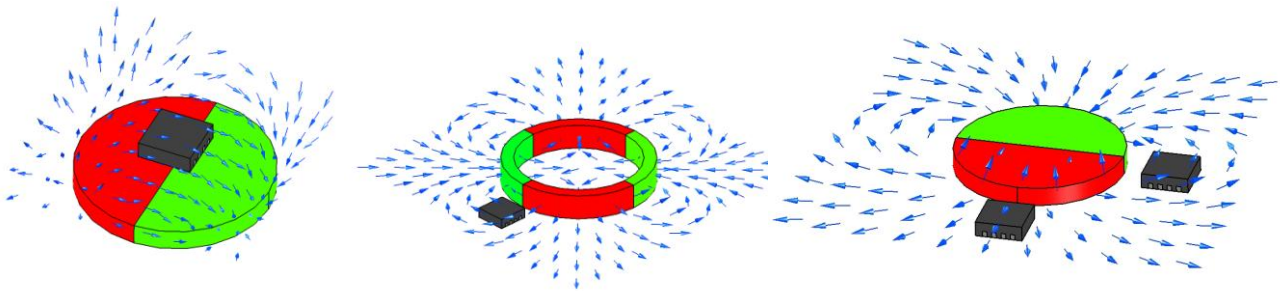

A rotating magnetic field in the surface parallel to the chip (x-y plane) will therefore deliver two independent sinusoidal output signals, one following a  $\cos(2\alpha)$  and the second following a  $\sin(2\alpha)$  function,  $\alpha$  being the angle between sensor and field direction (see Figure 2).

The KMT32B magnetic field sensor is suited for high precision angle measurement applications at a regular field strength of  $H_0 \geq 25$  kA/m (generated for example with magnet 67.044 from Magnetfabrik Bonn at a distance of 5.2 mm at room temperature). With reduced accuracy, the sensor KMT32B may be used with a field strength of  $H_0 \geq 14$  kA/m (at room temperature; be aware of the influence of the earth magnetic field!). Most magnets show a decreasing field strength with temperature while the magnetic field direction is unchanged.

## FEATURES

- Contactless angular position, ideal for harsh environments
- Design optimized for linearity
- High accuracy
- Low cost, low power
- Self diagnosis feature
- Attractive SMD packages
- User has complete control over signal evaluation
- Extended operating temperature range (-40 °C to +150 °C, +160°C on request)
- REACH & RoHS compliant (lead free)

## APPLICATIONS

- Absolute and incremental angle measurement
- Automotive (steering angle, torque)
- Robotics
- Camera positioning
- Potentiometer replacement
- Position measurement in medical applications
- Motor motion control

# KMT32B Magnetic Angle Sensor

## CHARACTERISTIC VALUES

Parameter	Symbol	Condition	Min	Typ	Max	Unit
<b>A. Operating Limits</b>						
Max. supply voltage	$V_{CC,max}$				<b>10</b>	V
Max. current (single bridge)	$I_{CC,max}$				<b>4</b>	mA
Operating temperature	$T_{op}$		<b>-40</b>		<b>+150</b>	°C
Storage temperature	$T_{st}$		<b>-40</b>		<b>+150</b>	°C
<b>B. Sensor Specifications (T=25 °C)</b>						
Supply voltage	$V_{CC}$			<b>5</b>		V
Resistance (single bridge)	$R_b$		<b>2400</b>	<b>3000</b>	<b>3600</b>	$\Omega$
Output signal amplitude	$V_{PEAK}$	Condition A, B	<b>9</b>	<b>11</b>	<b>13</b>	mV/V
Offset voltage	$V_{OFF}$	Condition A, B	<b>-1</b>	<b>0</b>	<b>+1</b>	mV/V
Angular inaccuracy	$\Delta\alpha$	Condition A, B		<b>0.05</b>	<b>0.2</b>	deg
Angular hysteresis	$\Delta\alpha H$	Condition A, B			<b>0.1</b>	deg
<b>C. Sensor Specifications</b>						
TC of amplitude	TCSV	Condition A, C	<b>-0.36</b>	<b>-0.32</b>	<b>-0.28</b>	%/K
TC of resistance	TCBR	Condition A, C	<b>+0.27</b>	<b>+0.32</b>	<b>+0.37</b>	%/K
TC of offset	TCVoff	Condition A, C	<b>-4</b>	<b>0</b>	<b>+4</b>	$\mu V/V/K$

Stress above one or more of the limiting values may cause permanent damage to the device. Exposure to limiting values for extended periods may affect device reliability.

## MEASUREMENT CONDITIONS

Parameter	Symbol	Unit	Condition
<b>Condition A: Set Up Conditions</b>			
Ambient temperature	T	°C	T = 25 °C (unless otherwise noted)
Supply voltage	$V_{CC}$	V	$V_{CC} = 5 V$
Applied magnetic field	H	kA/m	H = 25 kA/m
<b>Condition B: Sensor Specifications (360° turn , <math>V_{Omax}&gt;0</math>, <math>V_{Omin}&lt;0</math>)</b>			
Output signal amplitude	$V_{PEAK}$	mV/V	$V_{PEAK} = (V_{Omax} - V_{Omin})/2/V_{CC}$
Offset voltage	$V_{OFF}$	mV/V	$V_{OFF} = (V_{Omax} + V_{Omin})/V_{CC}$
Angular inaccuracy	$\Delta\alpha$	deg	$\Delta\alpha = MAX \alpha_0 - \alpha $ ; max. angular difference between actual field angle $\alpha_0$ and measured angle $\alpha$ due to deviations from ideal sinusoidal characteristics, calculated from the third and fifth harmonics of the Fourier spectrum; offset voltage error contributions not included
Angular hysteresis	$\Delta\alpha H$	deg	$\Delta\alpha H =  \alpha_{left\ turn} - \alpha_{right\ turn} $ angular difference between left and right turn

# KMT32B Magnetic Angle Sensor

## MEASUREMENT CONDITIONS

Parameter	Symbol	Unit	Condition
<b>Condition C: Sensor Specifications (-25°C, +125°C)</b>			
Ambient temperatures	T	°C	T <sub>1</sub> = -25 °C, T <sub>0</sub> = +25 °C, T <sub>2</sub> = +125 °C
TC of amplitude	TCSV	%/K	$TCV = \frac{1}{(T_2 - T_1)} \cdot \frac{\frac{\Delta V_n}{V_{cc}}(T_2) - \frac{\Delta V_n}{V_{cc}}(T_1)}{\frac{\Delta V_n}{V_{cc}}(T_1)} \cdot 100\%$
TC of resistance	TCSR	%/K	$TCR = \frac{1}{(T_2 - T_1)} \cdot \frac{R(T_2) - R(T_1)}{R(T_1)} \cdot 100\%$
TC of offset	TCVoff	(μV/V)/K	$TCV_{off} = \frac{V_{off}(T_2) - V_{off}(T_1)}{(T_2 - T_1)}$

## BLOCK DIAGRAM

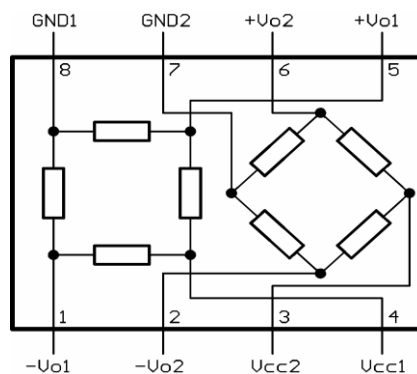

Figure 1: Circuit Diagram

## TYPICAL PERFORMANCE CURVES

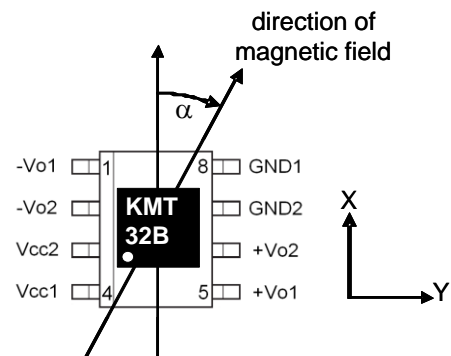
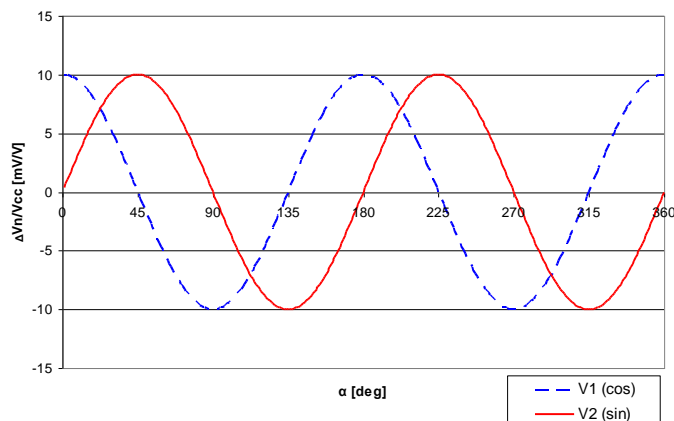
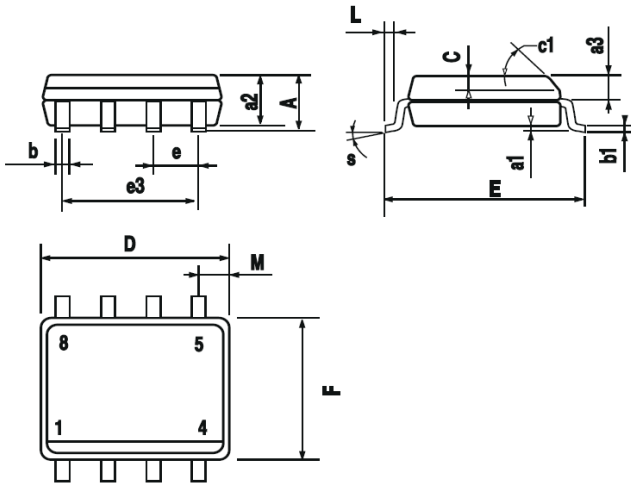

Figure 2: Characteristic curves for KMT32B (SO8, TDFN)

# KMT32B Magnetic Angle Sensor

## PACKAGES

### SO8



DIM.	mm			inch		
	MIN.	TYP.	MAX.	MIN.	TYP.	MAX.
A			1.75			0.069
a1	0.1		0.25	0.004		0.010
a2			1.65			0.065
a3	0.65		0.85	0.026		0.033
b	0.35		0.48	0.014		0.019
b1	0.19		0.25	0.007		0.010
C	0.25		0.5	0.010		0.020
c1	45° (typ.)					
D (1)	4.8		5.0	0.189		0.197
E	5.8		6.2	0.228		0.244
e		1.27			0.050	
e3		3.81			0.150	
F (1)	3.8		4.0	0.15		0.157
L	0.4		1.27	0.016		0.050
M			0.6			0.024
S	8° (max.)					

### TDFN 2.5\*2.5

unit: mm

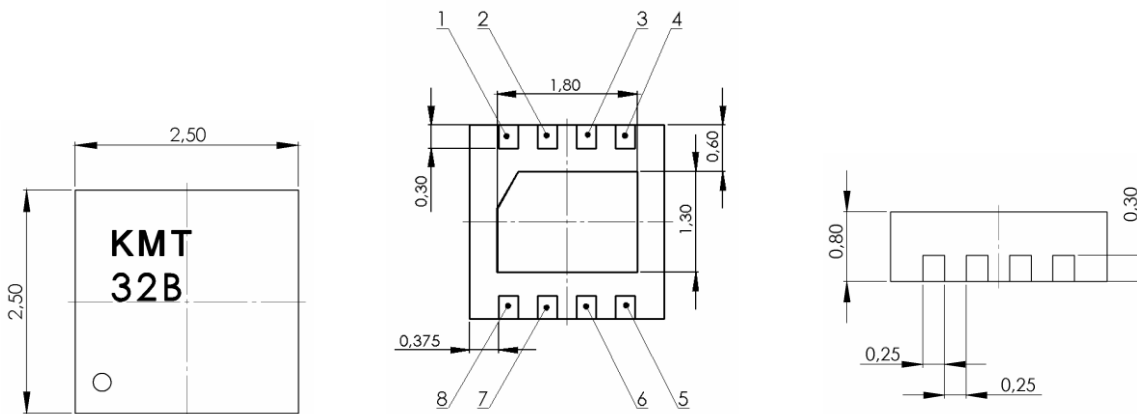

### RECOMMENDED SOLDER PAD LAYOUT FOR TDFN

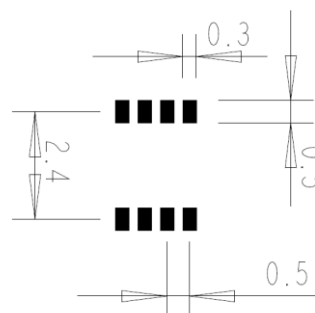

# KMT32B Magnetic Angle Sensor

## PIN ASSIGNMENT (SO8, TDFN)

Pin (SO8)	Pin (TDFN)	Symbol	Function
1	7	$-V_{o1}$	negative output bridge 1
2	8	$-V_{o2}$	negative output bridge 2
3	1	$V_{cc2}$	positive supply voltage bridge 2
4	2	$V_{cc1}$	positive supply voltage bridge 1
5	3	$+V_{o1}$	positive output bridge 1
6	4	$+V_{o2}$	positive output bridge 2
7	5	$GND_2$	negative supply voltage bridge 2
8	6	$GND_1$	negative supply voltage bridge 1

## SOLDER PROFILE

Recommended solder reflow process according to IPC/JEDEC J-STD-020D (Pb-Free Process)

## TAPE AND REEL PACKAGING INFORMATION

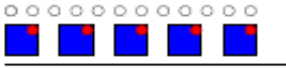
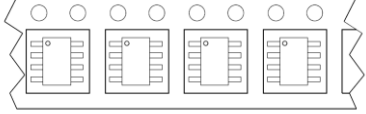
Description	Reel size	Units/reel	Pin 1 orientation	Note
KMT32B/TD	7"	3,000	Top-right of sprocket hole side	
KMT32B/SO	13"	2,500	Top-left of sprocket hole side	

# KMT32B Magnetic Angle Sensor

## ORDERING CODE

Device	Package	MOQ	Part Number
KMT 32B/SO	SO-8	1 reel	G-MRCO-015
KMT 32B/TD	TDFN 2.5 x 2.5	1 reel	G-MRCO-016

## ORDERING INFORMATION

NORTH AMERICA	EUROPE	ASIA
Measurement Specialties, Inc. 1000 Lucas Way Hampton, VA 23666 United States Phone: +1-800-745-8008 Fax: +1-757-766-4297 Email: <a href="mailto:sales@meas-spec.com">sales@meas-spec.com</a> Web: <a href="http://www.meas-spec.com">www.meas-spec.com</a>	MEAS Deutschland GmbH Hauert 13 D-44227 Dortmund Germany Phone: +49-(0)231-9740-0 Fax: +49-(0)231-9740-20 Email: <a href="mailto:info.de@meas-spec.com">info.de@meas-spec.com</a> Web: <a href="http://www.meas-spec.com">www.meas-spec.com</a>	Measurement Specialties China Ltd. No. 26, Langshan Road High-tech Park (North) Nanshan District, Shenzhen 518057 China Phone: +86-755-33305088 Fax: +86-755-33305099 Email: <a href="mailto:info.cn@meas-spec.com">info.cn@meas-spec.com</a> Web: <a href="http://www.meas-spec.com">www.meas-spec.com</a>

The information in this sheet has been carefully reviewed and is believed to be accurate; however, no responsibility is assumed for inaccuracies. Furthermore, this information does not convey to the purchaser of such devices any license under the patent rights to the manufacturer. Measurement Specialties, Inc. reserves the right to make changes without further notice to any product herein. Measurement Specialties, Inc. makes no warranty, representation or guarantee regarding the suitability of its product for any particular purpose, nor does Measurement Specialties, Inc. assume any liability arising out of the application or use of any product or circuit and specifically disclaims any and all liability, including without limitation consequential or incidental damages. Typical parameters can and do vary in different applications. All operating parameters must be validated for each customer application by customer's technical experts. Measurement Specialties, Inc. does not convey any license under its patent rights nor the rights of others.

# Mouser Electronics

Authorized Distributor

Click to View Pricing, Inventory, Delivery & Lifecycle Information:

[Measurement Specialties:](#)

[G-MRCO-016](#) [G-MRCO-015](#)